



AIR PRESSURE SENSING SWITCH WITH DUAL, INDEPENDENTLY ADJUSTABLE SET POINTS

APPLICATION

The Model DDP-109 is a general purpose proving switch designed for HVAC and Energy Management applications. The DDP-109 provides dual switching action: two separately-operated, independently-adjustable SPDT snap-acting switches are mounted on a common foot bracket. Differential pressures up to 2 inches w.c. can be measured. Because the two snap switches are set independently, an adjustable "deadband" can be established for control circuits requiring both high and low actuation points. Many control and alarm functions are possible: for instance, monitor two pressure sources and sense the differential for actuation at two independent set points.

GENERAL DESCRIPTION & OPERATION

Each of the two plated housings contains a diaphragm, a calibration spring and a snap-acting SPDT switch. There are two low pressure sample connections (one for each switch assembly), and a common high pressure sample connection (located on the foot bracket between the two low pressure connections). All three sample connections accept 1/4" OD metallic tubing via integral compression ferrule and nut fittings. An enclosure cover is provided for each switch assembly to guard against accidental contact with the live switch terminal screws and the set point adjusting screws. The enclosure covers accept a 1/2" conduit connection.

MOUNTING

Select a mounting location which is free from vibration. The DDP-109 must be mounted with the diaphragm in any vertical plane in order to obtain the lowest specified operating set point. Avoid mounting with the sample line connections in the "up" position. Surface mount via the two 3/16" diameter holes in the integral mounting bracket. The mounting holes are 7" apart.

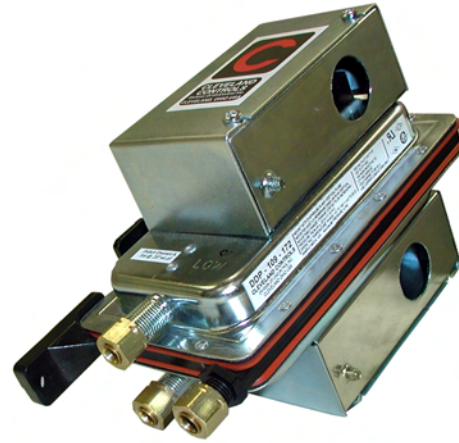

AIR SAMPLING CONNECTION

The DDP-109 is designed to accept firm-wall sample lines of 1/4" OD tubing by means of ferrule and nut compression connections. For sample lines of up to 10 feet, 1/4" OD tubing is acceptable. For lines up to 20 feet, use 1/4" ID tubing. For lines up to 60 feet, use 1/2" ID tubing. Adapters, suitable for slip-on flexible tubing are available: refer to Bulletin AFS08.01. Locate the sampling probe a minimum of 1.5 duct diameters downstream from the air source. Install the sampling probe as close to the center of the airstream as possible. Refer to the dimensions drawing to identify the common high pressure inlet "H" and the two low pressure inlets "L" (on Element A and Element B). For each element, select one of the following options and connect the sample lines as recommended.

POSITIVE PRESSURE ONLY: Connect the sample line to inlet H; inlet L remains open to the atmosphere.

NEGATIVE PRESSURE ONLY: Connect the sample line to inlet L; inlet H remains open to the atmosphere.

TWO NEGATIVE SAMPLES: Connect the higher negative sample to inlet L. Connect the lower negative sample to inlet H.

TWO POSITIVE SAMPLES: Connect the higher positive sample to inlet H. Connect the lower positive sample to inlet L.

ONE POSITIVE AND ONE NEGATIVE SAMPLE: Connect the positive sample to inlet H. Connect the negative sample to inlet L.

ELECTRICAL CONNECTIONS

For each element, before pressure is applied to the diaphragm, the switch contacts will be in the normally closed (NC) position. The snap switch has screw-type terminals with cup washers. For each element, wire alarm and control applications as shown in Figure 1.

FIELD ADJUSTMENT

The adjustment range of each of the 2 elements of the DDP 109 Air Switch is 0.05±.02" w.c. to 2.0" w.c.. To adjust an element's set point, turn the adjusting screw counterclockwise until motion has stopped. Next, turn the adjusting screw 4 complete turns in a clockwise direction to engage the spring. From this point, the next ten turns will be used for the actual calibration. Each full turn represents approximately 0.2" w.c. Please note: To properly calibrate an air switch, a digital manometer or other measuring device should be used to confirm the actual set point.



SPECIFICATIONS FOR MODEL DDP-109

Operating temperature range:
-40 to 176F (-40.0C to 80C).

Approvals: UL, CSA.
Shipping Weight: 1.5 lb. approx.

COMMON FOOT BRACKET:

Material: Cyclocac® T4500.

Sample Line Connector:

Male, externally threaded, 7/16"–24 UNS thread, complete with nut and self-aligning ferrule.

Sample Line Connection: Connector will accept 1/4" OD rigid or semi-rigid tubing (i.e., copper, aluminum or plastic). Tubing adaptors, suitable for slipping on flexible plastic tubing are available separately.

SWITCHING ELEMENT "B":

Mounting position: Diaphragm vertical.

Set Point Range: .05± .02" wc to 2.0" wc.

Field adjustable: "operate range" .07" wc to 2.0" wc.

Field adjustable: "release range" .04" wc to 1.9" wc.

Approximate switching differential:

Progressive; increasing from .02± .01" wc at minimum set point to approximately .1" wc at maximum set point.

Measured media: Air.

Life: 100,000 cycles minimum at 1/2 PSI maximum pressure each cycle and at maximum rated electrical load.

Electrical rating:

300 VA pilot duty at 115 to 277 VAC (60 Hz).
15a non-inductive to 277 VAC (60 Hz).

Contact arrangement: SPDT.

Position of switch contacts before pressure is applied: NC.

Electrical Connections: Screw-type terminals with cup washers.

Sample Line Connector:

Male, externally threaded, 7/16"–24 UNS thread, complete with nut and self-aligning ferrule.

Sample Line Connection: Connector will accept 1/4" OD rigid or semi-rigid tubing (i.e., copper, aluminum or plastic). Tubing adaptors, suitable for slipping on flexible plastic tubing are available separately.

SWITCHING ELEMENT "A":

Mounting position: Diaphragm vertical.

Set Point Range: .05± .02" wc to 2.0" wc.

Field adjustable: "operate range" .07" wc to 2.0" wc.

Field adjustable: "release range" .04" wc to 1.9" wc.

Approximate switching differential:

Progressive; increasing from .02± .01" wc at minimum set point to approximately .1" wc at maximum set point.

Measured media: Air.

Life: 100,000 cycles minimum at 1/2 PSI maximum pressure each cycle and at maximum rated electrical load.

Electrical rating:

300 VA pilot duty at 115 to 277 VAC (60 Hz).
15a non-inductive to 277 VAC (60 Hz).

Contact arrangement: SPDT.

Position of switch contacts before pressure is applied: NC.

Electrical Connections: Screw-type terminals with cup washers.

Sample Line Connector:

Male, externally threaded, 7/16"–24 UNS thread, complete with nut and self-aligning ferrule.

Sample Line Connection: Connector will accept 1/4" OD rigid or semi-rigid tubing (i.e., copper, aluminum or plastic). Tubing adaptors, suitable for slipping on flexible plastic tubing are available separately.

FOR EACH ELEMENT (A & B):

TO PROVE EXCESSIVE AIR FLOW OR PRESSURE:

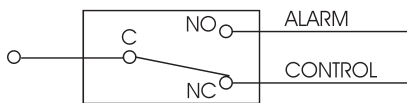

TO PROVE INSUFFICIENT AIR FLOW OR PRESSURE:

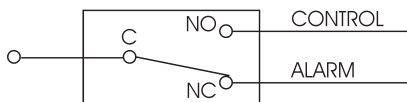
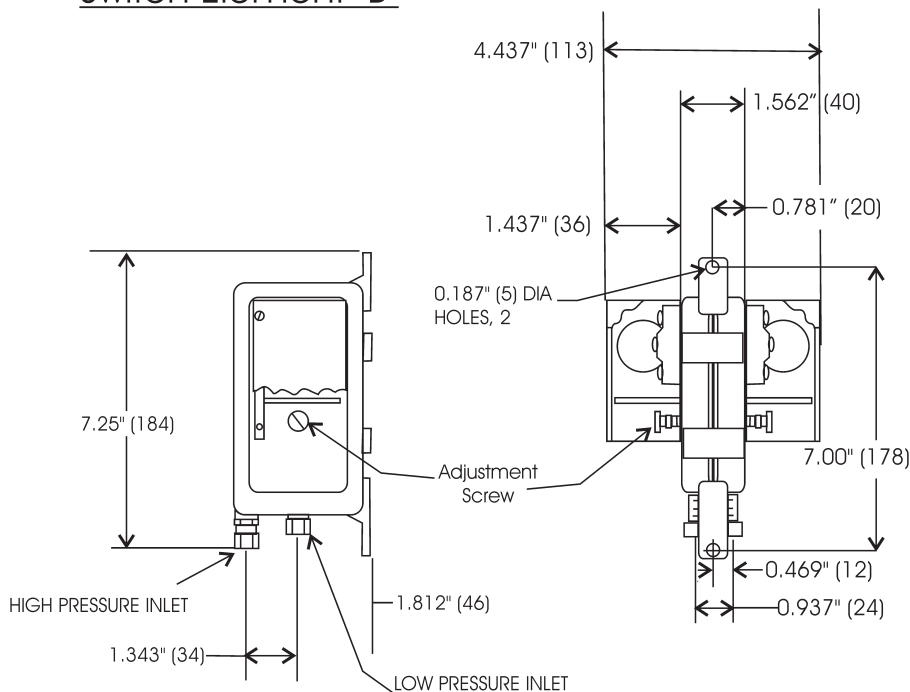

Figure 1

Switch Element "B"



Switch Element "A"

