

Model R-09400-B0 MASTER REGULATOR

FEATURES

- Single, self-contained, sensing, controlling, and actuating unit
- Continuous Maximum Firing Rate Selection
- Local or Remote Manual Operation
- Mounts in Any Position
- Rugged Construction
- Optional Handwheel for Local Manual Operation



APPLICATION

The Hays Cleveland Model R-09400-B0 MASTER REGULATOR is a self-contained, fully-automatic firing rate controller, combining sensing element, response mechanism, and power actuator in one compact unit. It regulates fuel or air supply or both in direct proportion to pressure or temperature demand signals.

OPERATION

In steam pressure systems, a bellows in the MASTER REGULATOR is connected by a sample line to the boiler header. In water temperature systems, the bellows is connected by a capillary tube to an immersion bulb in the header.

Pressure or temperature changes cause the bellows to react on sensing switches feeding electrical signals to a reversible motor. A gear reduction drive shaft is connected to a lead screw, the rotation of which moves a drive tube connected by mechanical linkage to a lever arm of units to be positioned.

The lead screw also operates the feedback mechanism to make corrections proportional to the load demands.

Used in single boiler positioning systems, the MASTER REGULATOR is its own complete, self-contained system for positioning fuel or air or both, maintaining a selectable pressure or temperature control set point. Remote position indication and automatic or manual operation is available.

HOW TO ORDER

The basic catalog number for the Hays Cleveland Model R-09400-B0 MASTER REGULATOR is 94. To this model designation add suffixes B through HH to build the complete catalog number for your particular instrument. Selection of the suffix numbers can be made from the table by choosing the number adjacent to the desired function. Where a suffix is not applicable, use a zero. If no options are desired, complete the model number with a double zero.

If the Master Regulator is for water temperature applications, you will need to select range, capillary, and desired well or bulb. The direct immersion bulb is integral to the capillary when shipped. The wells are packed separately.

Typical Example: R-09410-2200-00

This is a Hays Cleveland Master Regulator for a single point

positioning steam application. Control range 20 to 100 psig. Set point: 60 psig. Actuator stroke is six inches, 60 seconds. Unit is encased in a standard dust-tight enclosure. Because it is a steam application, there is no capillary, wells, or bulbs. No handwheel.

MASTER REGULATOR MODEL DESIGNATION

R-09ABC-DEFG-HH

A. Type: Master Regulator (A=4)

B. Application:

- Without Potentiometer (B=1)
- With Potentiometer (B=2)

C. Local Manual Operation:

- N/A (C=0)
- Handwheel (C=1)

D. Stroke:

- 6-inch, 30 seconds [std] (D=1)
- 6-inch, 60 seconds [std] (D=2)
- 6-inch, 120 seconds [std] (D=3)

E. Control Range:

- 0 to 30 psig Steam Pressure (E=1)
- 20 to 100 psig Steam Pressure (E=2)
- 75 to 300 psig Steam Pressure (E=3)
- 300 to 800 psig Steam Pressure (E=4)
- 150 to 275F Water Temperature (E=5)
- 200 to 375F Water Temperature (E=6)
- 250 to 450F Water Temperature (E=7)
- Special Range (E=9)

F. Capillary (With Water Temperature Models Only):

- N/A [Steam Pressure Models] (F=0)
- 10 ft. [std] (F=1)
- 20 ft. (F=2)
- 30 ft. (F=3)
- 40 ft. (F=4)
- 50 ft. (F=5)
- 60 ft. (F=6)
- 70 ft. (F=7)
- Special Length (F=9)

G. Wells (With Water Temperature Models Only):

- N/A [Steam Pressure Models] (G=0)
- Removable Copper Well (G=1)
- Removable Stainless Steel Well (G=2)
- Non-Removable Direct Immersion Bulb (G=3)

HH. Options:

- N/A (HH=00)

SPECIFICATIONS

Pressure Ranges: 0 to 30, 20 to 100, or 75 to 300 psi.

Temperature Ranges: 150 to 275F, 200 to 325F, or 250 to 450F.

Power Requirements: 115 volts, 50/60 Hz; less than 1.0 amp power consumption.

Enclosure: Fully gasketed, dust-tight, heavy gauge construction.

Motor: Sealed, heavy-duty, gearhead, 60:1 reduction. Reversible, capacitor start-run permanently lubricated, dynamic breaking.

Switching: Sealed, positive snap-action switches with solid-state switching device.

End Switches: Two SPDT, rated 10 amps, at each end of stroke. Provide high and low fire interlocking for programming.

Stroke: 6 inch.

Full Stroke Time: 30, 60, or 120 seconds.

Thrust/Speed:

- 75 lbs./30 sec.
- 150 lbs./60 sec.
- 300 lbs./120 sec.

Adjustments: External knobs for controlling set point and firing rate. Internal sensitivity and proportional band adjustments.

Set Point: Adjustable to 1% of control range.

Potentiometer: 4000 ohm (9420 models only).

Wells:

- Separable copper: 1/2" NPT, Part Number 11868.
- Separable stainless steel: 1/2" NPT, Part Number 12177.
- Direct Immersion Bulb: 3/4" NPT, Part Number 13282.

Weight: 26 lbs. net (shipping weight 28 lbs.).

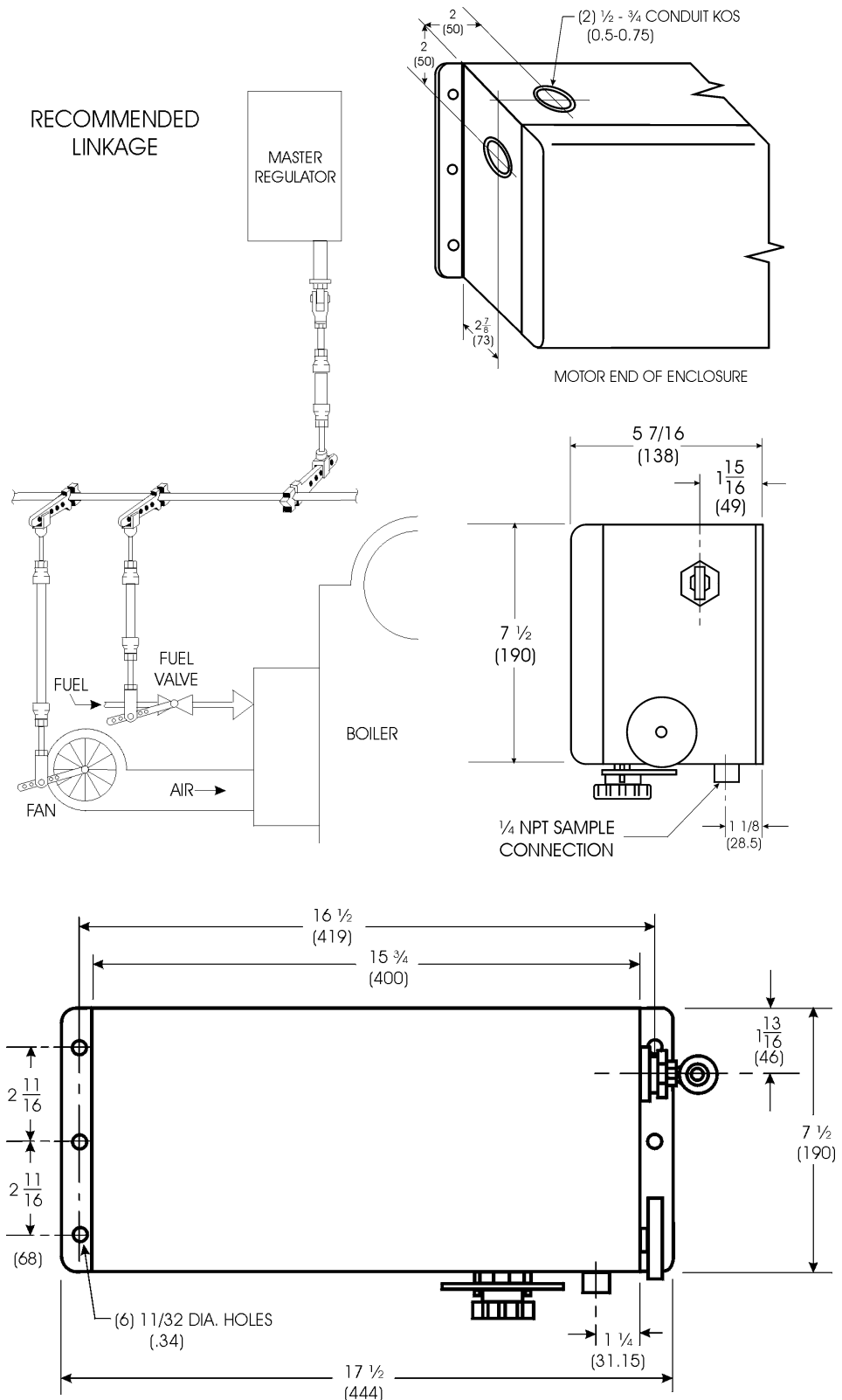

Visit us on the World Wide Web at www.hayscleveland.com

Hays Cleveland Div. of UniControl Inc.
 1903 South Congress Avenue
 Boynton Beach FL 33426
 Telephone: 561.734.9400
 Fax: 561.734.8060
 Email: salescombustion@unicontrolinc.com

Hays Cleveland Div. of UniControl Inc.
 1111 Brookpark Road
 Cleveland OH 44109
 Telephone: 216.398.4414
 Fax: 216.398.8558
 Email: salescombustion@unicontrolinc.com